

INSTALLATION AND OPERATING MANUAL FOR BUTTERFLY VALVES TTV

INSTALLATION INSTRUCTIONS

GENERAL GUIDELINES :

- Ensure that the valves to be used are appropriate for the conditions of the installation (type of fluid, pressure and temperature).
- Be sure to have enough valves to be able to isolate the sections of piping as well as the appropriate equipment for maintenance and repair.
- Ensure that the valves to be installed are of correct strength to be able to support the capacity of their usage.
- **Installation of all circuits should ensure that their function can be automatically tested on a regular basis (at least two times a year).**

INSTALLATION INSTRUCTIONS :

- **Before installing the valves, clean and remove any objects from the pipes** (in particular bits of sealing and metal) which could obstruct and block the valves.
- **Ensure that both connecting pipes either side of the valve (upstream and downstream) are aligned (if they're not, the valves may not work correctly).**
- **Make sure that the two sections of the pipe (upstream and downstream) match, the valve unit will not absorb any gaps. Any distortions in the pipes may affect the tightness of the connection, the working of the valve and can even cause a rupture. To be sure, place the kit in position to ensure the assembling will work.**
- **If sections of piping do not have their final support in place, they should be temporarily fixed. This is to avoid unnecessary strain on the valve.**
- The valve must be inserted between flanges with disc half opened but the disc must not overpass the valve thickness. Position the bolts to keep centered the valve. Then open fully the valve and tighten the bolts. **See graph under.**

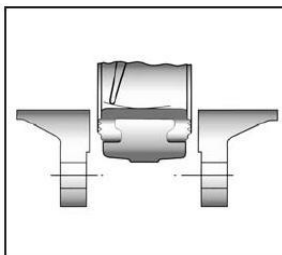

Half open valve introduction

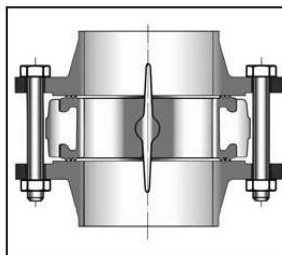

Complete opened disc valves when screw tightening

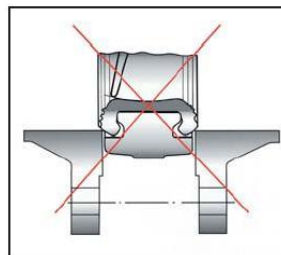

- Tighten the bolts in cross.
- The disc must move easily inside the pipe.
- Valves must be opened during cleaning operation.
- Tests must be done with a cleaned pipe.
- Tests must be done with opened valve. Test pressure must not be higher than the valve specification according to ISO 5208 or EN 12266-1.
- Then open slowly the valve.
- **Do not mount butterfly valves with stainless steel pressed collars and turning flanges without strias.**
- **And not on flat face flanges without strias (example : painted cast iron fittings)**

INSTALLATION AND OPERATING MANUAL FOR BUTTERFLY VALVES TTV

MAXIMUM TIGHTENING TORQUES FOR BOLTING FLANGES :

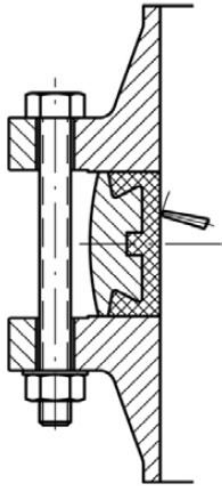

		Maximum torques (Nm)			
		Bolting types	5,6 / A307 Gr.B	8,8 / A193 B7	10,9
Bolting DN	M12 (1/2")	41,16	84,28	117,6	142,1
	M14 (9/16")	66,64	132,3	186,2	225,4
	M16 (5/8")	102,9	205,8	289,1	347,9
	M18 (3/4")	142,1	284,2	396,9	475,3
	M20 (3/4")	196	401,8	568,4	676,2
	M22 (7/8")	259,7	539	764,4	911,4
	M24 (1")	338,1	695,8	980	1176
	M27 (1"1/8)	499,8	1029	1470	1764
	M30 (1"1/4)	666,4	1421	1960	2352

ADVISABLE TIGHTENING TORQUES FOR BOLTING FLANGES :

DN	40	50	65	80	100	125	150	200	250	300	350	400	450	500	600
Bolting torque (Nm) Ps=10 Bars	60	60	65	70	75	95	115	130	155	165	160	200	195	240	305
Bolting torque (Nm) Ps=16 Bars	60	60	65	70	80	100	120	140	165	180	175	220	215	270	365
Bolting torque (Nm) Ps=25 Bars	65	65	70	75	80	110	135	150	180	210	200	270	260	345	505

These values are indicative and need to be adapted to the service conditions, the bolts used and the type of flanges used.

INSTALLATION AND OPERATING MANUAL FOR BUTTERFLY VALVES TTV

BEST POSITION INSTALLATION :

For wastewater, fluids with solid particles or cold network (air conditioning for example), the best position is the horizontal one :



- For an installation in ATEX area, check the conductivity between the valve, the upstream pipe and the downstream pipe and make sure the pipe is connected to the earth.

MAINTENANCE :

- We recommend to operate fully the valve 1 to 2 times per year.
- During maintenance operation, ensure that the pipe isn't under pressure, that there's no fluid in the pipe and that the valve is isolated. If there's a fluid in the pipe, evacuate it. Ensure that there are no risks due to the temperature or the fluid (like acids). If the fluid is corrosive, inert the installation before maintenance operation.

INSTALLATION AND OPERATING MANUAL FOR BUTTERFLY VALVES TTV

1) GENERAL

This instructions manual contains important information concerning the installation, operation, maintenance and storage of **TTV** butterfly valves. Please read carefully these instructions and keep them for future occasions. It is important that only well-informed and qualified people operate the valves.

2) WARNINGS

- Make sure that the valves are used within the limits established in the technical specifications
- Using the valves above the temperature limits can damage the internal and the external elements
- Using the valves above the pressure limits can damage the internal and the external elements
- Using the valve in corrosive environments, without the proper protection, can damage the internal and the external elements
- Do not try to dismantle any part of the valve while it is installed in the pipe, and do not do it neither if there is fluid inside
- Purge the whole installation, being sure there is no air inside when the fluid is liquid
- Do not dismantle the shaft while the valve is installed in the pipe; the disc would be carried away through the pipe due to the pressure of the fluid
- Make sure which is the rotation way of the valve when mounting any type of actuation (there are stops clearly marked and opening / closing icons of the disc at 90°)
- It is necessary that the customer specifies if the valves are to be installed at the pipeline end
- It is necessary to carry out an “open/close” test at least once a year
- TTV valves are delivered with seat placed inside with the valonas outward, so they do not need to use single assembly joint

3) WORKING CONDITIONS AND TECHNICAL INFORMATION

- Fluids : These valves are delivered for fluid as well as for gas services.
It is the customer’s responsibility or the Engineer which leads the project, the decision of choosing the most appropriate materials for the required service, as well as the evaluation of the installation risks.
- Working pressure:
These valves are delivered for a working pressure of 20 bar maximum.
- Working temperature:
The standard valves delivered are between the range of temperature: from -10°C to + 90°C.
- Ambient temperature:
The standard valves delivered are designed to work within the range: from -10°C to +80°C.
- Operation time:
These valves are delivered with a connecting flange as per ISO 5211.
The time of operation will vary depending on the type of operation mounted.
- Travel:
The standard construction has a rotating travel from 0 to 90 degrees and from 90 to 0 degrees.
- Lubrication:
TTV butterfly are not lubricated.
- Construction :
Movement transmission through the splined shaft and disc, designed for inside and outside installations.
- Protection and resistance against corrosion:
Every standard valve is delivered with protection against corrosion for normal environmental conditions. For this reason the valves undergo a process of Rilsanization (RILSAN Polyamide 11). Before installing the valves in agressive environmental conditions, make sure you have chosen the appropriate protection.
- The proper maintenance of valves involves cleaning of surface of valves. This procedure should be carried out softly and with neutral soap. This is advisable to carry out an “open/close” trial as well.
- Valves labelling and designation :
The type of valve, diameter, pressure design, maximum working pressure, lining, reference... are stated in the valve designation.
TTV valves are delivered with labels containing the following information: **TTV** anagram, type, model, type of operation, pressure design, maximum pressure, lining, manufacturing order, date and **CE** marking.

INSTALLATION AND OPERATING MANUAL FOR BUTTERFLY VALVES TTV

4) OPERATION AND WAY OF ROTATION

In order to close the valve, the shaft is moved clockwise; to open the valve, the shaft is moved in the opposite direction. The valve is regulated by means of the operation devices, which are the following:

a) Manual actuator with lever

The regulation is carried out by means of the notch flange and the lever's latch. For this purpose, the latch is clutched from the flange and it is turned in the appropriate direction to open or to close the valve.

Then the latch is clutched again in the flange in the desired position.

Up to DN200, there are 9 notches, from DN250 to 300, there no notchs, the lever is blocable in all positions.

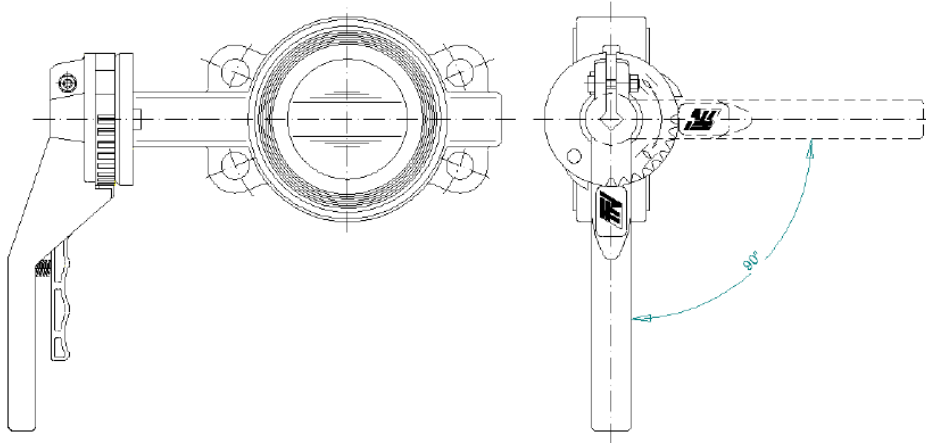

b) Manual actuator with Gearbox

The movement $\frac{1}{4}$ turn (90°) is made by a wheel's turning, which at the same time moves a wormshaft-quadrant.

The movement is regulated by the bolts (item 9 in the drawing below).

For this purpose the screw is loosened (position 8) and the bolt is introduced or taken out depending on how open or close the disc is required. We would proceed the same way to close the disc completely. It is necessary to check the indication arrow in the gearbox quadrant and the opening / closing icons of the gearbox.

There is no need to dismount any piece of the gearbox for this purpose.

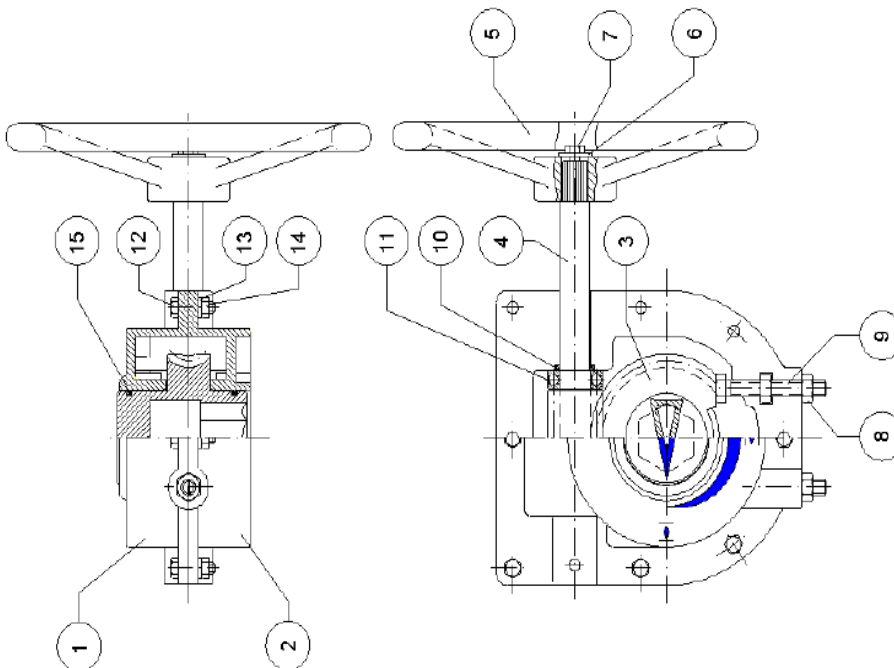

INSTALLATION AND OPERATING MANUAL FOR BUTTERFLY VALVES TTV

c) Pneumatic actuator

Request working instructions, assembly and maintenance for the specific actuator.

d) Actuator with electric actuator

Request working instructions, assembly and maintenance for the specific electric actuator.

5) INSTALLATION INSTRUCTIONS

5.1) Installation of Wafer and Flange type valves

The valves are usually delivered slightly open. Check they are so before mounting them. Once the space for the valve is checked, they are put in line in the pipe. Then some bolts are placed in the pipe.

The next step is to open the disc 90° and put the rest of the bolts with their nuts.

Finally it is proceed to tighten the nuts (following a triangular tightening scheme) with the purpose of having every bolt uniformly tighten and not producing any deformation in the liners.

We check that the valve can be opened and closed without any problem

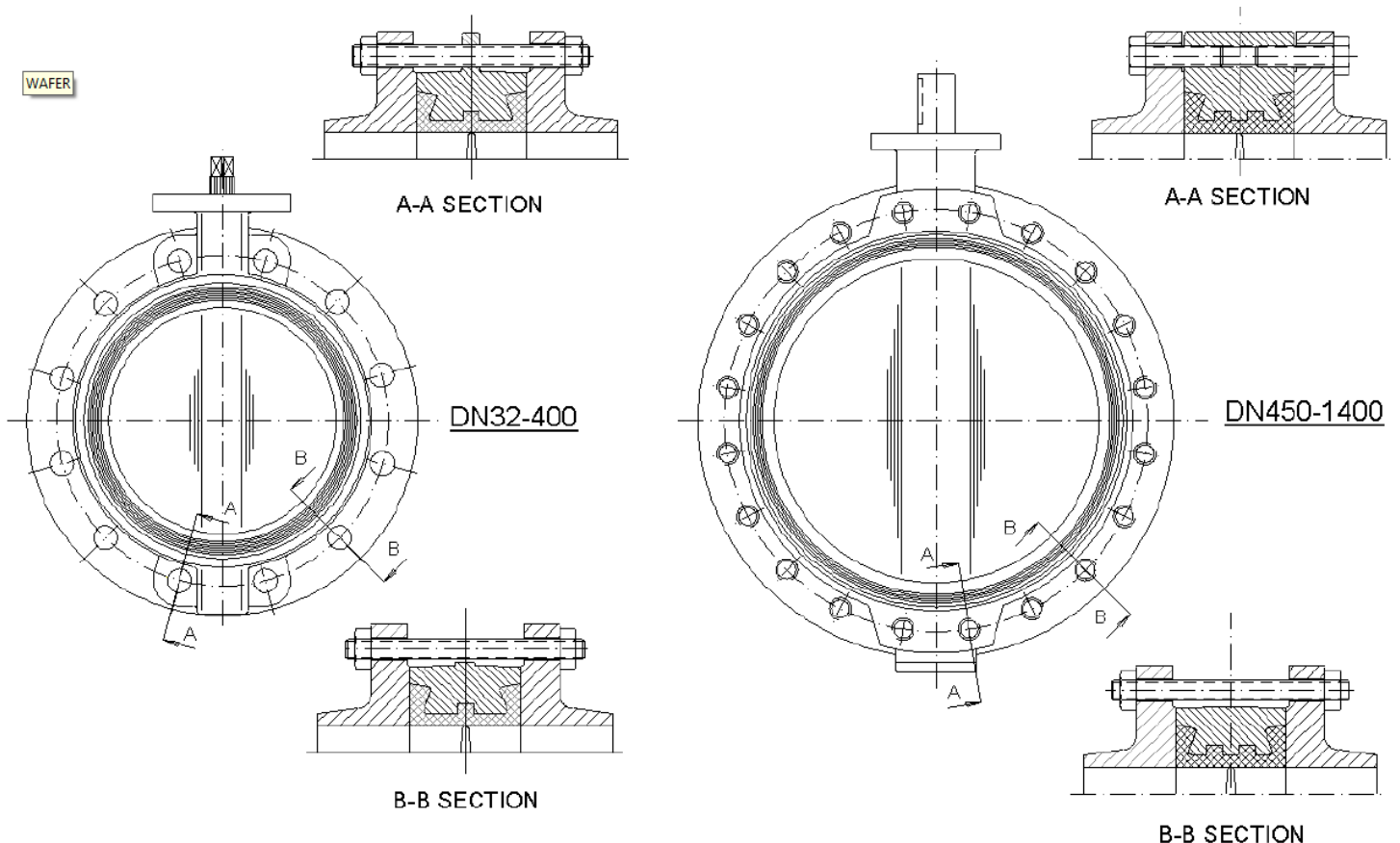

• **NOTE (ONLY TO BE APPLIED TO FLANGE TYPE VALVES):**

IT IS NOT ALLOWED TO USE SCREWS WITH NUTS TO FIX THE FLANGES OF THE VALVE TO THE PIPE FLANGES, THIS MUST BE DONE WITH COMPLETE PASSING BOLTS AND NUTS.

INSTALLATION AND OPERATING MANUAL FOR BUTTERFLY VALVES TTV

5.2) Installation of LUG type valve

It follows the same procedure detailed for the other type of valves.

These valves should be installed with screws, whose length allows the perfect tightening between the flanges and the pipe.

These screws cannot be longer than allowed.

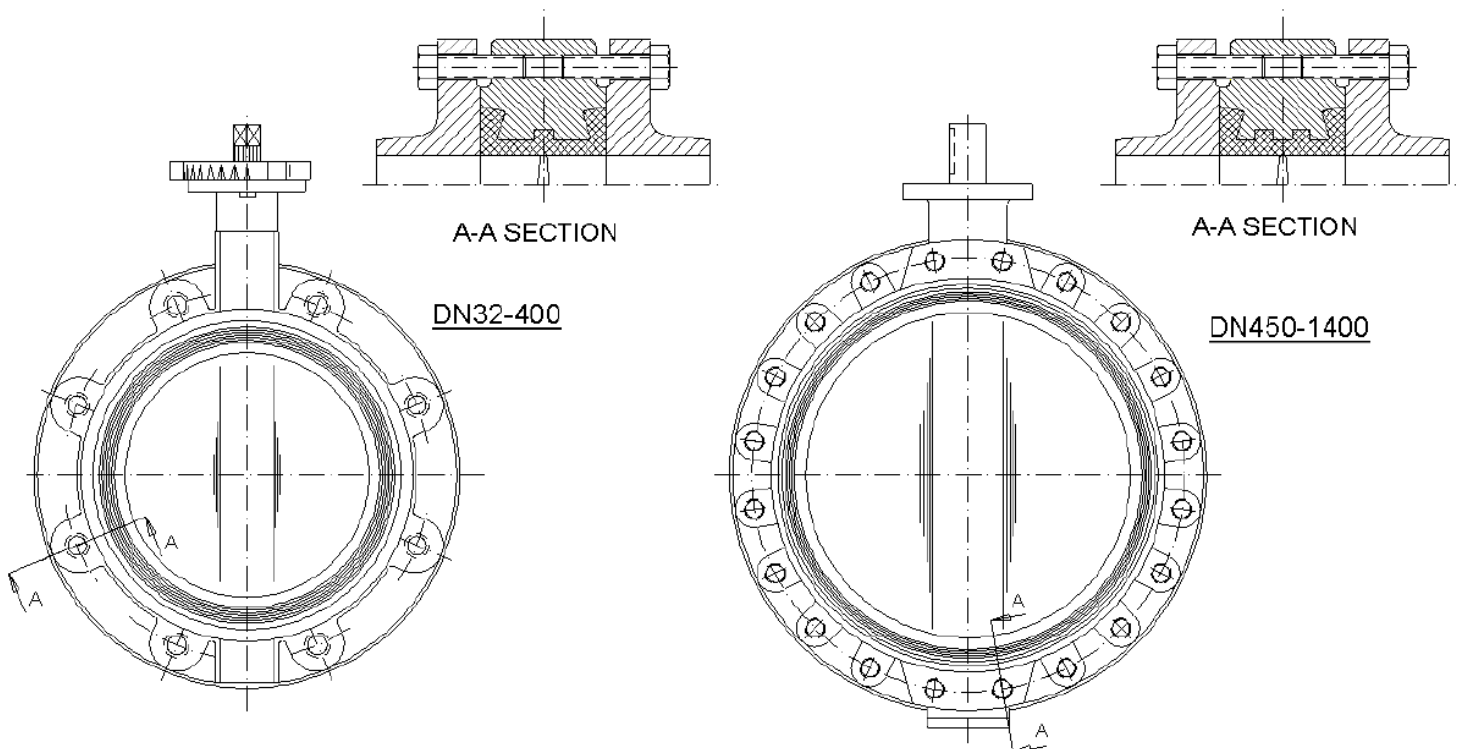

5.3) Mounting position

TTV recommends that valves from DN450 onward are installed with the shaft in horizontal position.

The valves are bidirectional. They can be installed on any side as it is not necessary to keep the fluids direction.

WARNINGS FOR INSTALLATION

- Before the valves are mounted, the liners have to be clean so as to guarantee the tightness of the valve.
- There has to be room for the valve to prevent the liner from any damage when introducing the valve.
- Be careful during its installation as the painting could be damaged.
- Make sure, during the assembling of heavy valves, that the louse and slings meet the security standards.

6) MAINTENANCE INSTRUCTIONS

TTV valves require little maintenance. However, due to the possible high working requirements, the following maintenance actions should be conducted, if so required.

INSTALLATION AND OPERATING MANUAL FOR BUTTERFLY VALVES TTV

The assembling and disassembling of the valve is only allowed to **TTV** staff or people specialised in this field. If these norms are not followed, then the guarantee will not have any validity.

6.1) Description and spare parts recommended.

6.1.1) Wafer, Lug and Flange type valves **DN32 to DN200.**

Remove the actuator and top adjustable flange (Fig. 6) by loosening the screws (pos. 9)
Using a screwdriver as a lever on the Circlip (Fig. 7) start taking the shaft off.

Take off the shaft completely and remove the disc (pos. 3 and 2).

Using the same screwdriver as a lever on the liner, and taking care not to damage the surface, push the liner to the inside until its final removal.

Replace the liner and O Rings with new ones (pos. 4 and 5).

By hand, without using any screwdriver, re-assemble the valve following inversely the above steps.

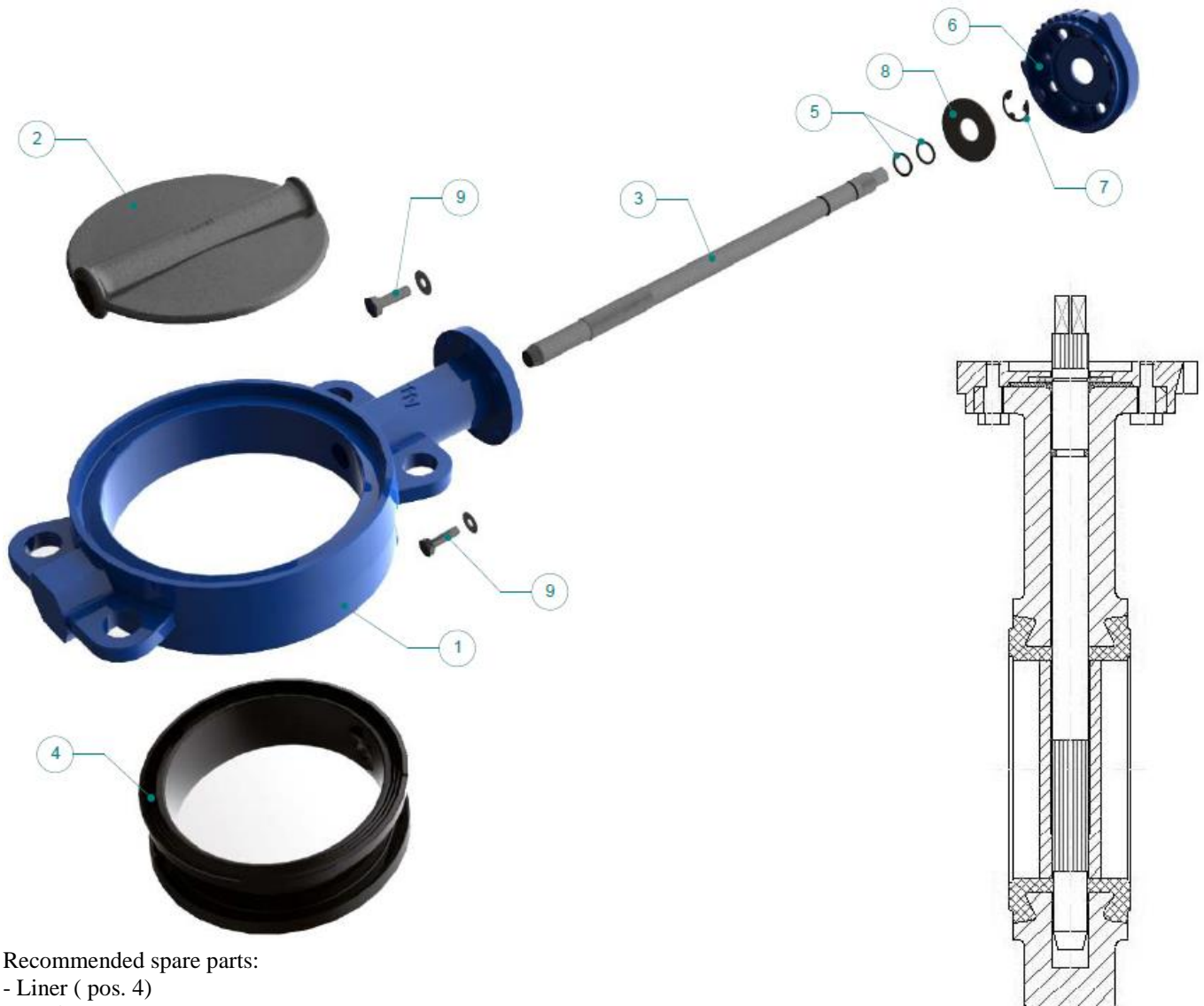

Recommended spare parts:

- Liner (pos. 4)
- O Rings (pos. 5)

INSTALLATION AND OPERATING MANUAL FOR BUTTERFLY VALVES TTV

6.1.2.) Wafer, Lug and flange Type valves from DN250 to DN400.

Remove the actuator and take out the spring (pos. 8) and the Washer (pos. 7).
Using a screwdriver as a lever on the Circlip (pos. 6) and proceed as described before.



Recommended spare parts:

- Liner (pos. 4)
- O Rings (pos. 5)

INSTALLATION AND OPERATING MANUAL FOR BUTTERFLY VALVES TTV

6.1.3) Wafer, Lug and Flange valves from **DN450** to **DN1400**.

Remove the actuator and take out the screws (pos. 12 and 11), removing the caps (pos. 9 and 10). Remove the screw (pos. 13).

Now the shaft is free and can be removed with an extractor, which will be placed in the threaded part of the shaft. Then the disc is removed and the liner is taken out.

For its installation, follow the opposite steps.



Warning: Due to diameter, weight and installation complexity, this process should be done in **TTV**.

Recommended spare parts:

- Liner (pos. 4)
- O'Rings (pos. 14, 15 and 16)

INSTALLATION AND OPERATING MANUAL FOR BUTTERFLY VALVES TTV

7) STORAGE INSTRUCTIONS

The aim of these specifications is the appropriate preservation and storage of TTV valves.

- Temperature

It would normally be no higher than 25 ° C

- Humidity

it should be avoided. There must not be condensations.

- Light

They have to protected against sun light and ultraviolet rays.

- Oxygen and Ozone

Protected from air in circulation and against Ozone.

- Deformation

They must be stored avoiding any deformation

- Contact with metals

The liners parts should not be in contact with copper or manganese.

- Contact with liquids

They must be kept away from dissolvents, grease, oil, acid...

- Contact with dusty materials.

They must be free from talcum powder, ceramic products ...

- Rotation of stored products

The older ones have to be used first

- Cleaning

If it is necessary to clean the valves, do not use abrasive products, trichloroetiline, hydrocarbon ...